



PRODUCT DATASHEET

TRACENET™ ECM™

ELECTRONIC CONTROL MODULE

APPLICATION

The TraceNet ECM is an electronic control module specifically designed for controlling electric heat trace circuits used in freeze protection and temperature maintenance applications. The ECM serves both the temperature control as well as the sensor and power connection for a heat trace circuit.

The ECM is housed in a glass reinforced nonmetallic enclosure with an environmental protection rating of IP66. Depending on options selected, the ECM may be used as a combination temperature control and limiter, a temperature controller with either low or high temperature alarm, or a temperature limiter. Rotary switches are provided for adjusting temperature control and limiter set points. The standard version of the ECM communicates on a physical network of RS485 by using a Modbus RTU communication protocol.

The ECM is approved for use in both ordinary (non-classified) and hazardous (classified) areas.

The ECM-OS is available in a stainless steel junction box for use in offshore applications. (Refer to Form TEP0138U)

RATINGS

Operating/control voltage... 120 Vac +/- 10% 50/60 Hz
230 Vac +/- 10% 50/60 Hz

Operating ambient range
-60°C to 55°C (-76°F to 131°F)

Minimum ambient storage range -74°C (-100°F)

Control switch type options SPST and DPST
Switching current ratings¹

SPST
30/30/20 amps 25°C, 40°C, 55°C (77°F, 104°F, 131°F)

DPST
28/23/17 amps 25°C, 40°C, 55°C (77°F, 104°F, 131°F)

Alarm output current rating 2 A

Electrical connection terminal blocks³

Adjustable temp. control range
0°C to 500°C (32°F to 932°F)

Measurement range -60°C to 500°C (-76°F to 932°F)

Measurement accuracy (ambient).....
± 1°C (0°C to +55°C) ± 1.8°F (32°F to +131°F)
± 2°C (0°C to -60°C) ± 3.6°F (32°F to +131°F)

Temperature sensor(s)
100 Ohm three wire Platinum RTD

High temp. alarm/trip programmable
(auto or manual reset)

RTD input circuitry intrinsically safe (Ex i)

Life expectancy 250,000 cycles

CERTIFICATIONS/APPROVALS



Certificate SIRA 12ATEX5239X
II 2(2) G Ex eb mb [ib] IIC T4 Gb
II 2(2) D Ex tb IIIC T135°C IP66 Db



Certificate IECEx SIR 12.0103X
Ex eb mb [ib] IIC T4 Gb
Ex tb IIIC T135°C Db

ECM has additional hazardous approvals including:
CSA, TRCU, INMETRO

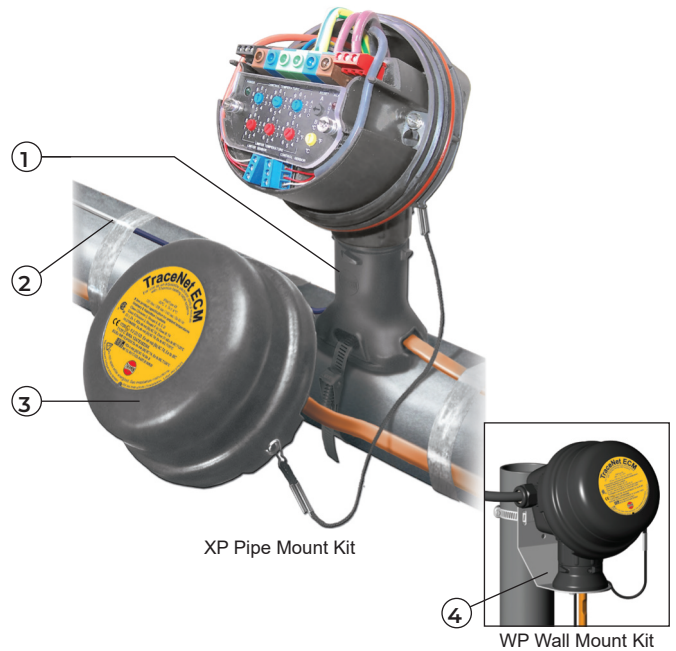

CONSTRUCTION

- 1 Pipe-mount expediter², glass-reinforced polymer
- 2 Three-wire RTD sensor (order separately)
- 3 Junction box, glass-reinforced polymer
- 4 316 Stainless Steel mounting bracket

PRODUCT FEATURES

- Encapsulated electronics and control
- One temperature control module for wide range of temperature control and limiter applications
- Energy saving accurate electronic temperature control action
- Data highway communication capability
- Selectable automatic or manual reset limiter action
- Control/limiter setting in degrees Centigrade or degrees Fahrenheit
- Combines power junction box and control module in one unit
- Also available as ambient thermostat (WP mount only)
- Refer to Form TEP0010U, System Accessories - Heat Tracing Cables for additional accessories.

Notes

1. When located outdoors and subject to solar gain, some current de-rating will be required. Contact Thermon for additional information.
2. The pipe mount expediter has a maximum pipe exposure temperature of 482°F (250°C).
3. The terminal blocks consist of:
(6) 10 mm² (8 AWG) line/load/PE terminals
(3) 3 mm² (12 AWG) comm. port terminals
(3) 3 mm² (12 AWG) alarm relay terminals
(2 x 3) 2.5 mm² (14 AWG) sensor terminals
See installation instructions for maximum wire size.

Sova Trading B.V. • Buitendijks 37 • 3356 LX Papendrecht • The Netherlands
Phone: +31 (0) 85 40 11 880 • Email: sales@sovatrading.com • www.sovatrading.com

Form TEP0128U-0621 © Thermon, Inc. • Printed in U.S.A. • Information subject to change.



PRODUCT DATASHEET
TRACENET™ ECM™
 ELECTRONIC CONTROL MODULE

PRODUCT REFERENCE LEGEND

ECM-CL-12-P-XP-SP	
Control Type	Switch Configuration
C = Controller (with low temp alarm)	SP = Single Pole (120 or 230 Vac)
CH = Controller (with high temp alarm)	DP = Double Pole (120 or 230 Vac)
CL = Controller and Limiter	Mounting Options
Comm. Network	XP = Pipe-Mount Expediter
1 = RS485	WP = Wall Mount Bracket with Expediter
	Cable Profile
	P = BSX, RSX, KSX, HTSX, USX, VSX-HT, HPT, FP
	R = TESH
	MI = MIS, MIQ
	Nominal Voltage Range
	1 = 120 Vac
	2 = 230 Vac

TYPICAL WIRING DIAGRAM (for controller with limiter)

Single Pole

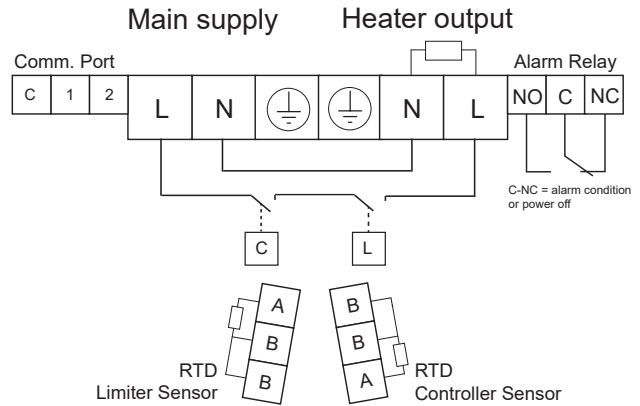

Double Pole

