



PRODUCT SPECIFICATIONS

# TraceNet™ ECM-OS™

## ELECTRONIC CONTROL MODULE

### APPLICATION

The TraceNet ECM-OS is an electronic control module specifically designed for the Offshore Industry to control electric heat trace circuits used in freeze protection and temperature maintenance applications. Available in wall (WP) mount version, the ECM serves both the temperature control as well as the sensor and power connection for a heat trace circuit.

The ECM-OS is housed in a stainless steel enclosure with an environmental protection rating of IP66. Depending on options selected, the ECM-OS may be used as a combination of temperature control and limiter, or as a temperature controller with either low or high temperature alarm. Rotary switches are provided for adjusting temperature control and limiter set points. The standard version of the ECM-OS communicates on a physical network of RS485 by using a Modbus RTU communication protocol. Additionally, an alternate 4-20mA communication network option is available.

The ECM-OS is approved for use in both ordinary (non-classified) and hazardous (classified) areas.

### RATINGS

Operating/control voltage ... 120 Vac+10%/-10% (50/60 Hz)  
230 VAC+10%/-10% (50/60 Hz)

Operating ambient range ..... -60°C to 55°C

Minimum ambient storage range ..... -74°C

Control switch type options ..... SPST and DPST

Switching current ratings <sup>1</sup>

SPST ..... 30/30/20 amps (25°C, 40°C, 55°C)

DPST ..... 28/23/17 amps (25°C, 40°C, 55°C)

Alarm output current rating ..... 2 A

Electrical connection ..... terminal blocks<sup>2</sup>

Adjustable temp. control range ..... 0° to 500°C

Measurement range ..... -60° to 500°C

TMeasurement accuracy (ambient)

± 1°C (0°C to +55°C)

± 2°C (0°C to -60°C)

Temperature sensor(s) 100 Ohm three wire Platinum RTD

High temp. alarm/trip ..... programmable  
(auto or manual reset)

RTD input circuitry ..... intrinsically safe (Ex i)

Life expectancy ..... 250,000 cycles

### CERTIFICATIONS/APPROVALS



II 2 (2) G Ex eb mb [ib] IIC T4 Gb SIRA 12ATEX5239X  
II 2 (2) D Ex tb IIIC T135°C IP66 Db



International Electrotechnical Commission  
IEC Certification Scheme for Explosive Atmospheres  
SIRA 12.0103X

ECM has additional approvals including: DNV, CSA

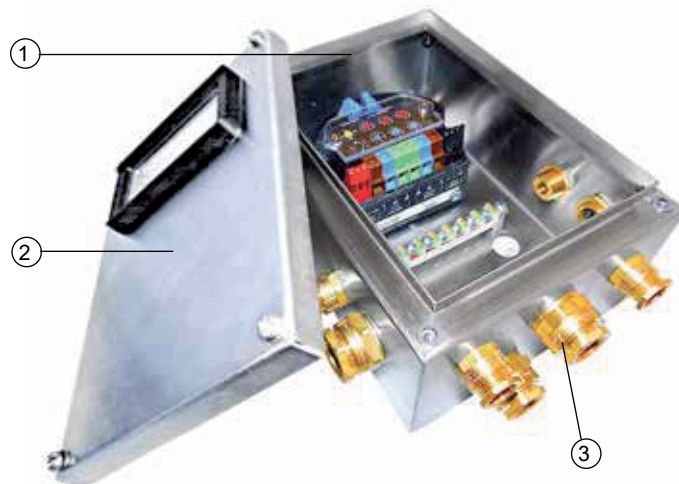

### CONSTRUCTION

- 1 Stainless steel box
- 2 Enclosure cover 2 mm with captive M6 stainless steel combo head screws and optional window
- 3 Available with metal and non-metallic glands

### PRODUCT FEATURES

- Encapsulated electronics and control
- One temperature control module for wide range of temperature control and limiter applications
- Energy saving accurate electronic temperature control action
- Data highway communication capability
- Selectable automatic or manual reset limiter action
- Control/limiter setting in degrees Centigrade or degrees Fahrenheit
- Combines power junction box and control module in one unit

#### Notes

1. When located outdoors and subject to solar gain, some current de-rating will be required. Contact Thermon for additional information.
2. The terminal blocks consist of:  
(6) 10 mm<sup>2</sup> line/load/PE terminals  
(3) 3 mm<sup>2</sup> comm. port terminals  
(3) 3 mm<sup>2</sup> alarm relay terminals  
(2 x 3) 2.5 mm<sup>2</sup> sensor terminals  
See installation instructions for maximum wire size.
3. Refer to Form TEP0010, System Accessories - Heat Tracing Cables for additional accessories.

Sova Trading B.V. • Buitendijks 37 • 3356 LX Papendrecht • The Netherlands  
Phone: +31 (0) 85 40 11 880 • Email: sales@sovatrading.com • www.sovatrading.com



PRODUCT SPECIFICATIONS

# TraceNet™ ECM-OS™

ELECTRONIC CONTROL MODULE

## PRODUCT REFERENCE LEGEND

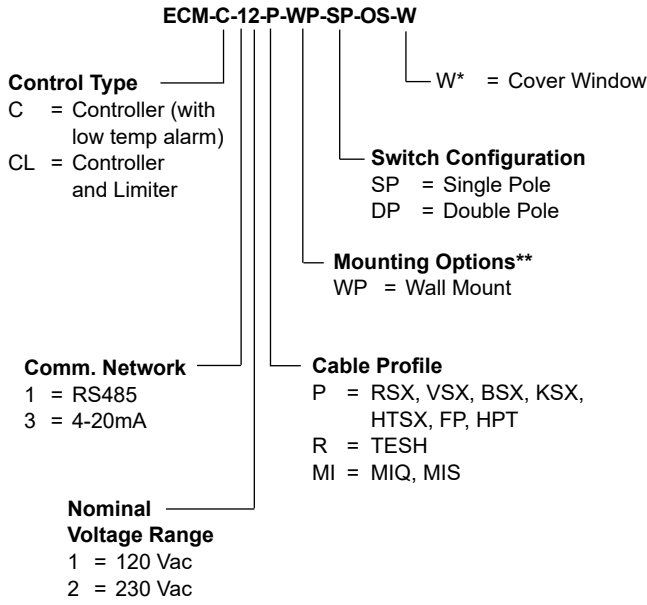

NOTE: \* = Optional  
 \*\* = for pipe mounting an additional stainless steel expeditor is available (order separately)

## TYPICAL WIRING DIAGRAM (for controller with limiter)

