



PRODUCT SPECIFICATIONS

Tracer Cable Glands non-metallic

APPLICATION

These polyamide cable glands are used for inserting permanent circular and non-circular cables into the enclosure. The glands are certified for use in ordinary (nonclassified) areas and in potentially explosive atmospheres in accordance with the ATEX Directive and the IECEx Scheme.

RATINGS / TECHNICAL DATA

Protection Class.....IP66/IP68 (EN60529)

DIMENSIONS

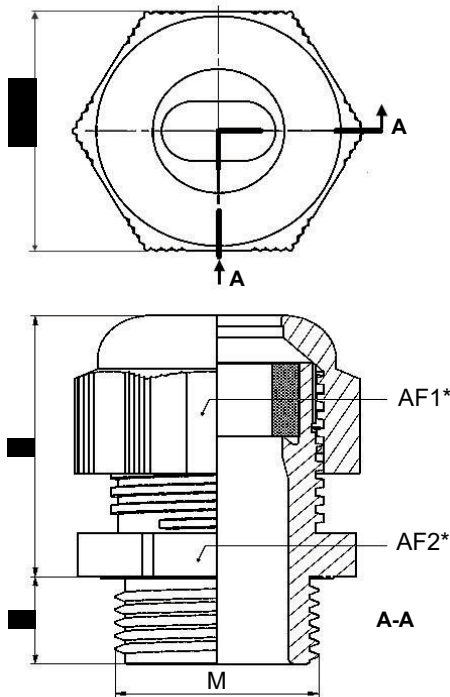

*AF= Width across flats

Item Name	Thread	L mm	H-max mm	AF1 mm	AF2 mm	Torque Value Nm	Seal Number	Ambient Temperature	Item Number	Cable
Trace Heat Gland M25-14-EXE (THERMON 14)	M25 x 1,5	10	30	24	27	4,5	FS2-13,5	-60°C to +80°C	38389	HTSX, KSX, FP
Trace Heat Gland M25-18-EXE (THERMON 18)	M25 x 1,5	10	32	27	27	5,5	FS3-16	-60°C to +80°C	38515-EAC	HPT, KSR
Trace Heat Gland M25-19-EXE (THERMON 19)	M25 x 1,5	10	37	33	33	8,0	FS1-21	-60°C to +80°C	452.001.019	BSX, FLX
Trace Heat Gland M25-20-EXE (THERMON 20)	M25 x 1,5	10	37	33	33	8,0	FS2-21	-60°C to +80°C	452.001.020	VSX, RSX
Power Gland M20 EXE + PT100 + TESH (8161 7-13)	M20 x 1,5	10	33	24	24	1,5	-	-60°C to +75°C	453.104.430	TESH, also for PT100 / Power



CONSTRUCTION

- Gland Body & Cap Nut..... Polyamide
- Sealing..... Silicon
- Color Black
- UV resistant

CERTIFICATIONS / APPROVALS





Tracer Glands M25-14 Ex, M25-18 Ex, M25-19 Ex, M25-20 Ex:



 IMQ 13ATEX025X
 II 2 G Ex e IIC Gb
 II 2 D Ex tb IIIC Db

 International Electrotechnical Commission
 IEC Certification Scheme for Explosive Atmospheres
 IMQ13.008X

Tracer Gland M20 Ex:



 IMQ 14ATEX1008X
 II 2 G Ex e IIC Gb
 II 2 D Ex tb IIIC Db

 International Electrotechnical Commission
 IEC Certification Scheme for Explosive Atmospheres
 PTB 14.0011X

THERMON The Heat Tracing Specialists®

Sova Trading B.V. • Buitendijks 37 • 3356 LX Papendrecht • The Netherlands
 Phone: +31 (0) 85 40 11 880 • Email: sales@sovatrading.com • www.sovatrading.com